

THIS DRAWING IS UNPUBLISHED. RELEASED FOR PUBLICATION
 (C) COPYRIGHT 19 BY AMP INCORPORATED. ALL RIGHTS RESERVED.

LOC	DIST	REVISIONS					
DF	DO	P	LTR	DESCRIPTION	DATE	DWN	APVD
		G		REV PER 063D-0520-00	7-03	CT	DM

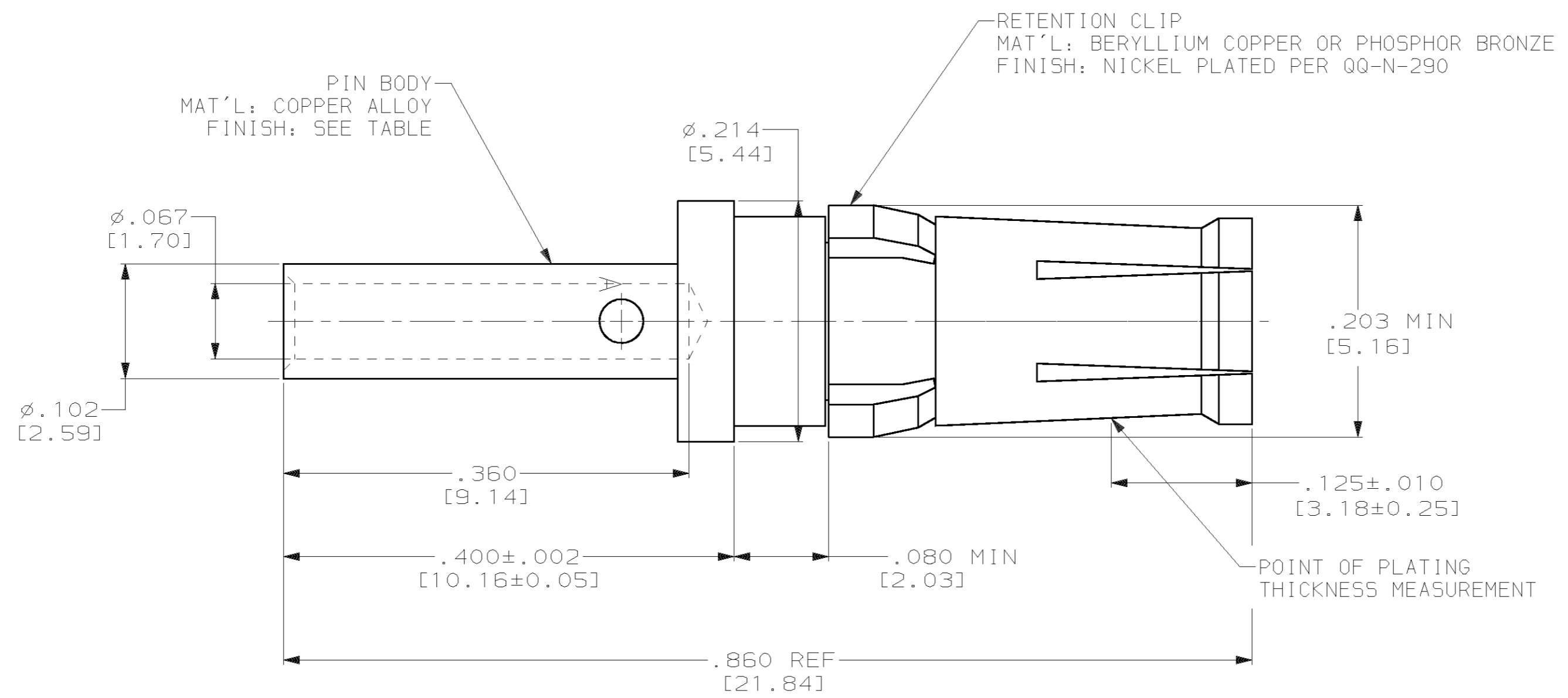

- THIS PART CONFORMS TO REQUIREMENTS FOR DANIELS CRIMP TOOL NO. FT8, WITH DANIELS POSITIONER PART NO. TP731, STRIP LENGTH .375, #16 AWG SETTING 8, #18 AWG SETTING 6.
- MATES WITH 212013-1 IN AMPLIMITE CONNECTOR ASSEMBLIES ONLY.
- FINISH: PLATED GOLD .000050 [0.00127] MIN THK PER MIL-G-45204 OVER NICKEL .000050 [0.00127] MIN THK PER QQ-N-290.
- FINISH: PLATED GOLD .000030 [0.00076] MIN THK PER MIL-G-45204 OVER NICKEL .000050 [0.00127] MIN THK PER QQ-N-290.
- WIRE BARREL WILL ACCEPT #16-#18 AWG WIRE.

PRELIMINARY NOT RELEASED FOR PRODUCTION	4	212014-2
	3	212014-1
	FINISH	PART NUMBER

THIS DRAWING IS A CONTROLLED DOCUMENT.		DWN	C.C. THOMAS	11/10/00
DIMENSIONS: INCHES [mm]		CHK	D. MILLER	11/10/00
TOLERANCES UNLESS OTHERWISE SPECIFIED:		APVD	D. MILLER	11/10/00
0 PLC \pm		PRODUCT SPEC	108-10045	
1 PLC \pm		APPLICATION SPEC	114-10014	
2 PLC \pm		WEIGHT	-	
3 PLC $\pm .005$ [0.13]		SCALE	10:1	
4 PLC \pm		SHEET	1 OF 1	
ANGLES \pm		REV	G	
SEE CALLOUTS		CUSTOMER DRAWING		

AMP AMP Incorporated
 Harrisburg, PA 17105-3608

ASSEMBLY, SOCKET CONTACT
 POWER VIII, #16 & #18 AWG

SIZE: A2 CAGE CODE: 00779 DRAWING NO: 212014 RESTRICTED TO: -